

REVIEW ON LANDSLIDE DETECTION BY USING WIRELESS SENSORS & GSM

KALPESH KISHOR JOSHI

Pursuing ME (ENTC) from G. H. Raisoni College of Engineering and Management, Ahmednagar, India

ABSTRACT

This paper introduces analysis of landslide detection based on wireless sensor network and GSM. And also here we introduce some other methods used for detection of landslide. We are also trying to give short information about our proposed method which is implanting next paper. This paper presents an independent landslide monitoring system based on wireless sensor networks and GSM. Provides real time measurement of various constraints such as amount of rainfall, moisture, and movement of land when trees and rocks are about to fell and also drive of the land as landslide occurs due to the earthquake are read by the microcontroller. The planet Earth has hundreds of impact events, with some occurrences causing both in terms of human casualty as well as economic losses. Such attitudes of earth pushed the frontiers to develop innovative monitoring strategies for the earth system. To make that real, although, will require coherent and real-time data by observing the earth behavior contiguously. Here sensors are very powerful device which used for real time monitoring. For removing such type occurrences we choose the sensor network and GSM. The sensor is a major device in electronics for measuring physical data from the environment. In the direction of the landslide prediction, sensor can play a great role, where sensor connected with wireless protocol can make it very useful for remote areas landslide mapping, detection, analysis and prediction etc. A wireless sensor network consists of spatially distributed autonomous sensors to monitor physical or environmental conditions, including temperature, sound, pressure, etc. is found be worthwhile.

KEYWORDS: ARM 7 LPC2138, GSM/GPRS, Landslide Monitoring, Sensor

INTRODUCTION

Landslide is a frequently occurring natural hazard in hilly regions. Major landslide prone areas in india are the himalayas, indo-burmese range, western and eastern ghats, nilgiris, and vindhya region. it affects around 15% of land area of india, which accounts approximately 0.5 million square kilometer. A landslide, also known as a landslip, is a form of mass wasting that includes a wide range of ground movements, such as rockfalls, deep failure of slopes, and shallow debris flows. Landslides can occur in underwater, called a submarine landslide, coastal and onshore environments. Although the action of gravity is the primary driving force for a landslide to occur, there are other contributing factors affecting the original slope stability. Typically, pre-conditional factors build up specific sub-surface conditions that make the area/slope prone to failure, whereas the actual landslide often requires a trigger before being released. Landslides should not be confused with mud flows, a form of mass wasting involving very to extremely rapid flow of debris that has become partially or fully liquified by the addition of significant amounts of water to the source material. There are different types of landslides which are shown below.

- Debris Flow
- Earth flows

- Debris Landslide
- Sturzstrom
- Shallow Landslide
- Deep Seated Landslide
- Causing Tsunami

To overcome such type landslide we are trying to implement new different technology. In this paper we are going to use different types of sensors like temperature measurement, soil measurement sensor for a detection of landslide and also we are going to use GSM and different types of controller for processing. Real-time monitoring of environmental disasters is one of the prime necessities of the world. Different technologies have been developed for this purpose. Wireless sensor networks (WSN) are one of the major technologies that can be used for real-time monitoring. WSN has the capability of large scale deployment, low maintenance, scalability, adaptability for different scenarios etc. WSN has its own limitation such as low memory, power, bandwidth etc., but its capability to be deployed in hostile environment, and low maintenance requirement made it one of the best suited technologies for real-time monitoring. In this landslide monitoring system would have GSM technique introduced in it. This is used for long distance information transfer and immediate rescue operation. The various details gathered by the rain sensor, humidity sensor and accelerometer sensor. Will be sent to the server present in the emergency unit this enables to take precautionary measures for the landslide. The GSM modem transmits the short message service to the server system which is connected wireless. By using APR9600 voice the information is alerted to nearby places. In this paper GSM and sensors are processed with the help of controller.

ANALYSIS OF EXISTING TECHNOLOGY

Dr. P. D. Sable, Prof. S.B.Shinde, Mule S.S., Pawar S.S., Tamboli J.K. they introduces research on 'Landslide Investigation in Bhore Taluk: A Case Study of Mahadevadi'. They collect the rock and soil sample. In their project the stream can be divided in 30m distance and each point we taken the GPS reading means latitude, longitude and elevation of that point and also shown the geological and geomorphologic characteristics of rock and soil. The all stream is studied up to it can be meet to the backwater of Bhatghar dam. The first stage of project is the survey of stream and next stage is the collection of sample of each point and testing the soil and rock sample and their results can be compare to ASTM. After testing they decide this specific area is prone to landslide. If the area is prone to landslide we providing the remedial measures [1]. In reference [2] they introduces propose of wireless sensor network (WSN) architecture for landslide prediction in the rocky mountain Regions of the Konkan Railways. They focus on modeling of the landslide strain data and subsequent distributed decision algorithm. They simulate pressure variation on rock samples in a tested at IIT-Bombay and measure the corresponding strain. This strain data is modeled using variable mean Gaussian process (VMGP). They examine different distributed decision algorithms and that the Distributed Scalar Based Detection (DSBD) gives as good results as the centralized detection (CD) scheme with respect to probability of missed detection, probability of false alarm, with lesser energy consumption at nodes. Receiver Operating Characteristic (ROC) curves is presented to compare the relative performance of different schemes.

Pravin Kumar Mishra and S.K.Chaulya discusses the development of a wireless sensor network (WSN) to detect landslides, which includes design and development of WSN for real time monitoring system. A laboratory trial has been

performed using wireless sensor networking with the integration of different sensors to detect the landslide [3]. By A.Dinagar, P.Karthick, K.Karthi, P.Tamilvanan, S.Premkumar present an accurate values detected from the sensors provided and when there is some changes from the threshold value which is set from the keypad, then GSM modem transmits the Short Message Service to the server system which is connected wireless. And the information is alerted to nearby places through voice output from the APR9600 voice module [4]. The deployment and data retrieval or collection from geophysical sensors, the design, development and deployment of WSN, the development of data collection and data aggregation algorithms needed for the network, and the network requirements of the deployed landslide detection system, data analysis system etc. has been discussed in this paper [5]. S. K. Shukla, S. K. Chaulya and R. Mandal they give brief discussion on (WSN) for landslide. The system consists of wireless nodes, gateway, base radio, server, geosensors and solar power arrangement. The system continuously monitors different parameters affecting landslide. Landslide prediction is done based on multivariate statistical analysis of various parameters and analytical hierarchy process method. The system provides different audio-visual alarms and short message services depending on prediction of landslide danger levels so that precautionary measures can be taken by nearby residents and local governing body. The paper also enumerates calibration procedure of geosensors used for landslide prediction by conducting laboratory trial in simulated condition [6].

By Pawan Nandkishor Hinge, Rohit Ramesh Bawage, Pallavi Nandkishor Hinge introduces “wireless sensor network detecting for vibrations before landslides”. In this paper, they have proposed theory to monitor landslides which occurs all of sudden and destroys village and mankind. In this theory, we have use accelerometer sensors to detect the small vibrations right before the avalanche occurs. The sensor module detects the vibrations from the field and sends the data to monitoring station through GSM module. Hence the data is observed on monitoring system and the alarm goes on hit whenever data crosses the threshold [7]. “GSM Based Real-Time Wireless Sensor Network for Landslide Detection” by Shrijan, S. B. Zaware, C. K. Kale, M. F. Mir introduces Wireless Sensor Network (WSN) appears to be the best suitable infrastructure to sense environmental parameters of our interests. This paper briefly addresses earth observation and areas of critical importance to people and society. The system monitors the changing geo-technical condition using various geo-technical sensors like soil moisture sensors, weight sensor, and tilt meter. This paper also touches upon the aspects of data transmission over Global System for Mobile Communication (GSM) to a remote data center. Here they give landslide pre warning [8]. Pooja Bahirat, Archana Chavan, Prajakta Pachange, and Prof. V.S.Kulkarni they use wireless sensor network an RF transceiver in paper “Wireless Sensor Network for Landslide Detection”. The landslide monitoring system presented in this paper is RF transceiver and provides real-time information about the current state of the monitored slope. Laboratory tests have been conducted to validate the performance of the monitoring system. After the landslide detection people alert by using buzzer or through SMS [9]. “Angular Variation Methodology for Landslide Measurement” introduces by Abdulkader Akolawala, Subha Subramaniam. In this paper they have proposed an Early Warning System developed using MEMS Accelerometer Sensor and Microcontroller for the prediction of Earth Quakes and Land Slides in Remote Area’s and the system is working based on GPS Location Identification to find out the co-ordinates. ARM LPC2148 Microcontroller is used for the verification of the proposed prototype model [10].

BLOCK DIAGRAM & RELATED WORK

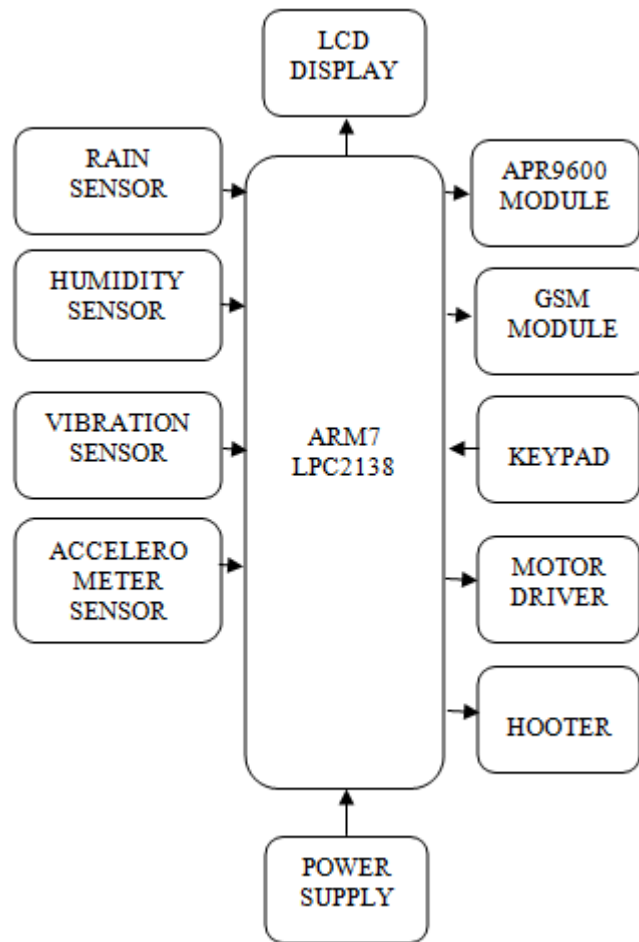

Figure 1: Specified Controller Diagram

Landslides are gravitational movements of soil or rock down slopes that can cause severe damage to environment. Numerous fatalities and structural failure caused by landslides have been reported over the years therefore, efforts to measure and to monitor potential landslides are essential to ensure human safety and to protect civil infrastructures. To observe the behavior of slopes, monitoring systems have been installed or manual inspections by human experts have been conducted.

Several measurement techniques have been proposed to identify slope instability and to estimate the risk of landslides. For example, map analyses and aerial and reconnaissance are used to assess the risk of landslides based on interpretation of terrain and geological information. These methods, however, are known to be costly and labor-intensive as well as highly subjective because results depend on the experience and the judgment of the human experts. Furthermore, landslide-indicating features in certain terrains cannot be identified by these techniques.

In this landslide monitoring system would have GSM technique introduced in it. This is used for long distance information transfer and immediate rescue operation. The various details gathered by the rain sensor, humidity sensor and accelerometer sensor. Will be sent to the server present in the emergency unit this enables to take precautionary measures for the landslide. The GSM modem transmits the short message service to the server system which is connected wireless.

By using APR9600 voice the information is alerted to nearby places.

A. Rain Sensor

A rain sensor or rain switch is a switching device activated by rainfall. There are two main applications for rain sensors. The first is a water conservation device connected to an automatic irrigation system that causes the system to shut down in the event of rainfall. The second is a device used to protect the interior of an automatic mode of windscreen wipers. An additional application in professional satellite communications antennas is to trigger a rain blower on the aperture of antenna feed, to remove water droplets from the Mylar cover that keeps pressurized and dry air inside the wave-guides.

B. Humidity Sensor

Based on a unique capacitive cell, these relative humidity sensors are designed for high volume, cost sensitive applications such as office automation, automotive cabin air control, home appliances, and industrial process control systems. They are also useful in all applications where humidity compensation is needed. The Humidity sensor is used to measure the amount of water present in air. The HH10D relative humidity sensor module is comprised of a capacitive type humidity sensor, a CMOS capacitor to frequency converter and an EEPROM used to hold the calibration factors. Due to the characteristics of capacitor type humidity sensor, the system can respond to humidity change very quickly. Each sensor is calibrated twice at two different accurate humidity chambers and two unique sensor related coefficients are stored onto the EEPROM on the module.

C. Vibration Sensor

Vibration sensor is also called as piezoelectric sensor. A piezoelectric sensor is a device that uses the piezoelectric effect to measure pressure, Acceleration, strain or force by converting them to an electrical charge. The three main modes of vibration sensor operations are transverse, longitudinal and shear. Transverse effect a force is applied along a neutral axis (y) and the charges are generated along the (x) direction, perpendicular to the line of force. The amount of charge depends on the geometrical dimensions of the respective piezoelectric element. Longitudinal effect the amount of charge produced is strictly proportional to the applied force and is independent of size and shape of the piezoelectric element. Using several elements that are mechanically in series and electrically parallel is the only way to increase the charge output.

D. Accelerometer Sensor

It is a 3 Axis Acceleration Sensor Board based on ADXL3XX from Analog devices. It is a first generation 3 axis acceleration sensor. User could get acceleration value of X, Y, and Z axis. And it is widely used in shock, slope, and moving detection. Output sensitivity could be select by simply set voltage level on few pins. The output of MMA7260Q is analog mode, so you need a A/D converter to read the acceleration value. The input voltage of accelerometer sensor is 3.3V. The output data would be a analog data. This analog value is than converted into digital value using ADC before applying to microcontroller. The features of Accelerometer sensor are 3-axis sensing small, low profile package 4 mm × 4 mm × 1.45 mm, Supply operation: 1.8 V to 3.6 V, Supply operation is 1.8V to 3.6V, 10,000g shock survival, It has excellent Temperature stability, Bandwidth adjustment with a single capacitor per axis. The Applications of accelerometer sensors are tilt sensing applications, Image stabilization, sports and health devices.

E. APR9600 Voice Module

APR9600 is a low cost high performance sound record/replay IC incorporates flash analogue storage technique. Recorded sound is retained even after power supply is removed from the module. The replayed sound exhibits high quality with a low noise level. Sampling rate for a 60 recording period is 4.2 kHz that gives a sound record/replay bandwidth of 20Hz to 2.1 kHz. However, by changing an oscillation resistor, a sampling rate as high as 8.0 kHz can be achieved. This shortens the total length of sound recording to 32 seconds.

Total sound recording time can be varied from 32 seconds to 60 seconds by changing the value of the single resistor. The IC can operate in one of two modes serial mode and parallel mode. The APR9600 has a 28 pin DIP package. Supply voltage is between 4.5V to 6.5V. During recording and replaying, current consumption is 25mA. An idle mode, the current drops to 1uA. An 8-16 ohm speaker is to be used with the module. Users can select different modes using the mode selection switch. The module is measured 80mm*55mm. APR9600 voice module which gives voice message alerting nearby places in danger.

F. GSM

GSM (Global System for Mobile Communications, originally *Groupie Special Mobile*), is a standard set developed by the European Telecommunications Standards Institute (ETSI) to describe technologies for second generation (or "2G") digital cellular networks. Developed as a replacement for first generation analog cellular networks, the GSM standard originally described a digital, circuit switched network optimized for full duplex voice telephony. The standard was expanded over time to include first circuit switched data transport, then packet data transport via GPRS. Packet data transmission speeds were later increased via EDGE. The GSM standard is succeeded by the third generation (or "3G") UMTS standard developed by the 3GPP. GSM networks will evolve further as they begin to incorporate fourth generation (or "4G") LTE Advanced standards. "GSM" is a trademark owned by the Association. The GSM Association estimates that technologies defined in the GSM standard serve 80% of the world's population, encompassing more than 5 billion people across more than 212 countries and territories, making GSM the most ubiquitous of the many standards for cellular networks. If the threshold value is exceeded the GSM (Global System for Mobile Communication) will send a warning message to the emergency server units. If it continues to exceed the threshold value, indicating severe landslide the GSM module will send a short message to emergency unit.

G. Hooter

Hooters are used in a system to indicate or to grab the attention regarding an emergency situation occurred. Buzzer act as a panic horn which indicates the need of instant attention as the condition goes haywire.

H. DC Motor

Here we use two DC motor to close the gates at the start and end. When landslide will detect that time by using DC motor we close the gates which goes inside to that area so we can save the lives and property.

ADVANTAGES

- Safety and security
- Safety for the humans and vehicles

- Safety for the animals
- Real time monitoring
- So easy to install
- Low power consumption
- Seismic Hazard landslide and Earthquake monitoring

CONCLUSIONS

Present study describes some of the important characteristics and application of sensor networking systems for landslide detection along four lane roads in hilly area. The study is equally applicable in monitoring of landslides prone areas. Study concludes about early warning of landmass likely to fail in due course of time.

In this project we have researched literature survey from that we concluded that Landslide detection is one of the challenging research areas available today in the field of geophysical research. And so that I decided to work on that and I make schematic design to detect the landslides by using different type of sensors like temperature sensor, soil moisture sensor and humidity sensor and also using GSM to inform the police station and hospital about landslides By using this entirety to take action to minimize the losses due to landslides.

REFERNCES

1. Dr. P. D. Sable, Prof. S.B.Shinde, Mule S.S., Pawar S.S., Tamboli J.K., "Landslide Investigation in Bhore Tahsil: A Case Study of Mahadevadi", International Journal of Engineering Science and Computing, April 2016.
2. Prakshep Mehta, Deepthi Chander, Mohamed Shahim, Kalyana Tejaswi, S. N. Merchant and U. B. Desai, "Distributed Detection for Landslide Prediction using Wireless Sensor Network", iitb.ac.in.
3. P. K. Mishra, S. K. Shukla, S. Dutta, S. K. Chaulya and G. M. Prasad, "Detection of Landslide Using Wireless Sensor Networks", IEEE-2011
4. A.Dinagar¹, P.Karthick², K.Karthi³, P.Tamilvanan⁴, S.Premkumar⁵, "Landslide Monitoring System with GSM Module", IJIRCCE, Vol. 3, Special Issue 2, March 2015
5. Maneesha V. Ramesh, Sangeeth Kumar, and P. Venkat Rangan, "Wireless Sensor Network for Landslide Detection", Amrita University- India 690525
6. S. K. Shukla, S. K. Chaulya, R. Mandal, B. Kumar, P. Ranjan, P. K. Mishra, G. M. Prasad, S. Dutta, V. Priya, S. Rath, K. Buragohain, P. C. Sarmah, "Real-Time Monitoring System for Landslide Prediction Using Wireless Sensor Networks", IJMCTR, Volume-2, Issue-12, December 2014
7. Pawan Nandkishor Hinge, Rohit Ramesh Bawage, Pallavi Nandkishor Hinge, "Wireless Sensor Network for Detecting Vibrations Before Landslides", IJERT, Vol. 3 Issue 10, October- 2014

11. Shrijan, S. B. Zaware, C. K. Kale, M. F. Mir, “GSM Based Real-Time Wireless Sensor Network for Landslide Detection”, IJARCSSE, Volume 5, Issue 2, February 2015
12. Pooja Bahirat, Archana Chavan, Prajakta Pachange, Prof. V.S.Kulkarni, “Wireless Sensor Network for Landslide Detection”, Innovation in engineering science and technology (NCIEST-2015)
13. Abdulkader Akolawala, SubhaSubramaniam, “Angular Variation Methodology for Landslide Measurement”, IJESC, ISSN-2321 -3361 © 2015